



## CLASS 300 STAINLESS STEEL GATE VALVE

Fig# GT 300SSF10

### Applicable Standards:

Steel Gate valves, API 603

Steel Gate valves, ASME B16.34

Face to Face, ASME B16.10

End Flange, ASME B16.5

Inspection and Test, API 598

### Design:

OS&Y, Outside Screw and Yoke

Flexible Wedge

Forged T-head Stem

Rising stem and Conical Gear Actuator

Valve MFG in Accordance with NACE MR0175 Specifications

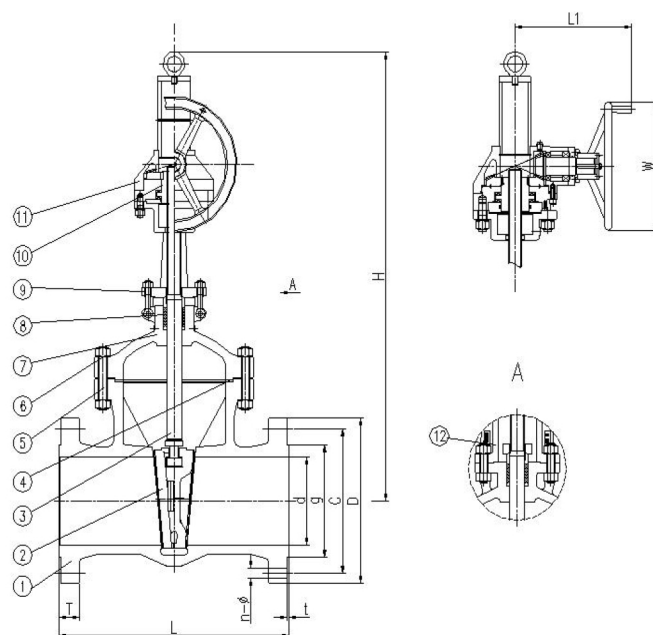

NO	PART NAME	MATERIAL
1	Body	A351-CF8M
2	Disc	A351-CF8M
3	Stem	A276-316
4	Gasket	A276-316+PTFE
5	Bonnet	A351-CF8M
6	Bonnet Bolt	A193-B8M

NO	PART NAME	MATERIAL
7	Nut	A194-8M
8	Packing	PTFE
9	Gland Flange	A351-CF8
10	Stem Nut	ZCuAl10Fe3
11	Conical Gear Actuator	C.S
12	Yoke	A351-CF8

NPS	Typical Dimensions(in)					Class 300Lb Flange Dimensions(in)							WT Lbs
	d	L	L1	H	W	D	C	g	T	t	n	Φ	
14	14	30	16.96	72.83	24	23	20.25	16.25	2.12	0.06	20	1.1/4	1855
16	16	33	16.96	75.6	24	25.5	22.5	18.5	2.25	0.06	20	1.3/8	2416
18	18	36	16.96	98.4	24	28	24.75	21	2.37	0.06	24	1.3/8	3172
20	20	39	19.9	110.2	32	30.5	27	23	2.5	0.06	24	1.3/8	3956
24	24	45	19.9	129.9	32	36	32	27.25	2.75	0.06	24	1.5/8	6213