



CLASS 150 STAINLESS STEEL GATE VALVE

Fig# GT 150SSF10

Applicable Standards:

- Steel Gate valves, API 603
- Steel Gate valves, ASME B16.34
- Face to Face, ASME B16.10
- End Flange, ASME B16.5
- Inspection and Test, API 598

Design:

- OS&Y, Outside Screw and Yoke
- Flexible Wedge
- Forged T-head Stem
- Rising stem and Conical Gear Actuator
- Valve MFG in Accordance with NACE MR0175 Specifications

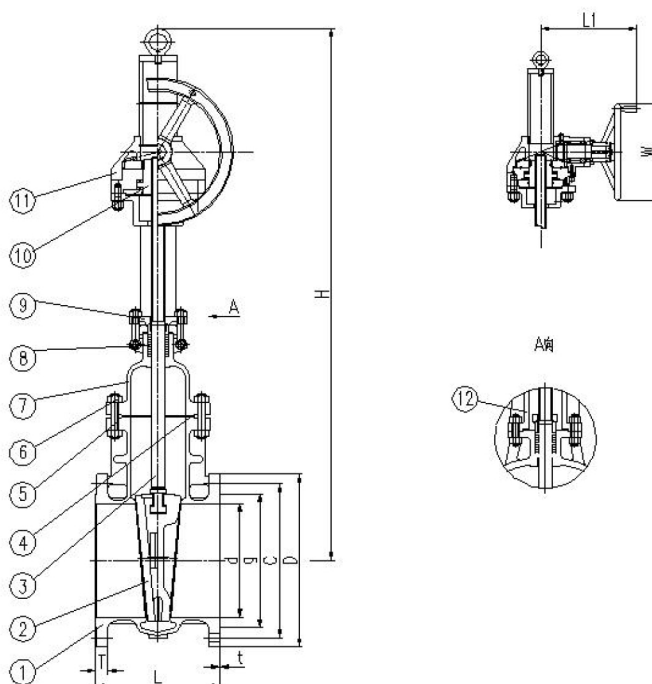

NO	PART NAME	MATERIAL
1	Body	A351-CF8M
2	Disc	A351-CF8M
3	Stem	A276-316
4	Gasket	A276-316+PTFE
5	Bonnet	A351-CF8M
6	Bonnet Bolt	A193-B8M

NO	PART NAME	MATERIAL
7	Nut	A194-8M
8	Packing	PTFE
9	Gland Flange	A351-CF8
10	Stem Nut	ZCuAl10Fe3
11	Conical Gear Actuator	C.S
12	Yoke	A351-CF8

NPS	Typical Dimensions(in)					Class 150Lb Flange Dimensions(in)							WT Lbs
	d	L	L1	H	W	D	C	g	T	t	n	Φ	
14	14	15	13.2	62.99	18.11	21	18.75	16.25	1.37	0.06	12	1.1/8	880
16	16	16	13.2	72.83	18.11	23.5	21.25	18.5	1.44	0.06	16	1.1/8	1221
18	18	17	13.2	82.68	18.11	25	22.75	21	1.56	0.06	16	1.1/4	1593
20	20	18	17	94.5	24	27.5	25	23	1.68	0.06	20	1.1/4	1844
24	24	20	17	112.2	24	32	29.5	27.25	1.87	0.06	20	1.3/8	2849